

Cross Creek Community Development District

3501 Quadrangle Boulevard, Suite 270, Orlando, FL 32817; Phone: 407-723-5900, Fax: 407-723-5901

www.crosscreekcdd.org

The meeting of the Board of Supervisors of the **Cross Creek Community Development District** will be held **Tuesday, January 23, 2024, at 11:30 a.m. at the Holiday Inn Sarasota-Airport, 8009 15th Street East, Sarasota, FL 34243**. The following is the proposed agenda for this meeting.

Call in number: 1-844-621-3956

Passcode: 2538 286 6774

Join from the meeting link

<https://pfmccd.webex.com/meet/ripollv>

NOTE: If you are calling into the meeting by phone or WebEx, please MUTE your line!

BOARD OF SUPERVISORS' MEETING AGENDA

Organizational Matters

- Call to Order
- Roll Call
- Public Comment Period *[for any members of the public desiring to speak on any proposition before the Board limited 2 minutes]*
- 1. Consideration of the Minutes of the October 24, 2023, Board of Supervisors' Meeting

Business Matters

2. Consideration of Resolution 2024-01, Election of Officers
3. Consideration of Resolution 2024-02, Designating Authorized Signatories for the District's Bank Account(s)
4. Ratification of Advanced Aquatics Services, Inc. Agreement
5. Update on Conveying Land Back to CDD and Getting More from the Developer Regarding Appraisal
6. Discussion of Barbeque Grill Replacement/Repair
7. Review and Consideration of Pool Resurfacing Proposal
8. Discussion Pertaining to Addition of a Gym to the Amenities Center
9. Ratification of Payment Authorizations 225 - 234
10. Review of District Financial Statements

Other Business

- Staff Reports
 - District Counsel
 - District Engineer
 - District Manager



- Supervisor Requests
- Audience Comments

Adjournment



**Cross Creek
Community Development District**

Consideration of the Minutes of the October 24,
2023, Board of Supervisors' Meeting

MINUTES OF MEETING

**CROSS CREEK COMMUNITY DEVELOPMENT DISTRICT
BOARD OF SUPERVISORS' MEETING**

**Tuesday, October 24, 2023, at 11:30 a.m.
Holiday Inn Sarasota - Airport
8009 15th Street East, Sarasota, FL, 34243**

Board Members Present were:

Charlie Tokarz	Chairperson
Connor Chambers	Vice Chairperson
Kathy Beccia	Assistant Secretary
Bruce Stolarz	Assistant Secretary
Lianna Litwin	Assistant Secretary

Also present were:

Venessa Ripoll	District Manager - PFM Group Consulting LLC
Kwame Jackson	PFM Group Consulting LLC (via Webex)
Jennifer Glasgow	PFM Group Consulting LLC (via Webex)
Andy Cohen	District Counsel- Persson Cohen & Mooney, P.A.
Charlie McKinnies	Medallion Home
Chris Chavez	Medallion Home

FIRST ORDER OF BUSINESS

Organizational Matters

Call to Order and Roll Call

Ms. Ripoll called the meeting to order at 11:30 a.m. and confirmed quorum.

Public Comment Period

No Public Comments.

**Consideration of the Minutes of
the May 23, 2023, Board of
Supervisors' Meeting**

The Board reviewed the minutes of the May 23, 2023, Board of Supervisors' Meeting.

On MOTION by Mr. Tokarz, seconded by Mr. Chambers, with all in favor, the Board accepted the minutes of the May 23, 2023, Board of Supervisors' meeting.

**Consideration of the Minutes of
the June 6, 2023, Board of
Supervisors' Meeting**

The Board reviewed the minutes of the June 6, 2023, Board of Supervisors' Meeting.

Ms. Ripoll stated Counsel's changes will be incorporated.

On MOTION by Mr. Tokarz, seconded by Mr. Chambers, with all in favor, the Board accepted the minutes of the June 6, 2023, Board of Supervisors' meeting with changes to be incorporated.

**Consideration of the Minutes of
the August 22, 2023, Auditor
Selection Committee Meeting**

The Board reviewed the minutes of the August 22, 2023, Auditor Selection Committee Meeting.

On MOTION by Mr. Tokarz, seconded by Mr. Chambers, with all in favor, the Board accepted the minutes of the August 22, 2023, Auditor Selection Committee Meeting.

**Consideration of the Minutes of
the August 22, 2023, Board of
Supervisors' Meeting**

The Board reviewed the minutes of the August 22, 2023, Board of Supervisors' Meeting.

Ms. Ripoll stated Counsel changes will be incorporated.

On MOTION by Mr. Tokarz, seconded by Mr. Chambers, with all in favor, the Board accepted the minutes of the August 22, 2023, Board of Supervisors' meeting with changes to be incorporated.

SECOND ORDER OF BUSINESS

Business Matters

**Discussion and Update on Land
Conveyance**

Ms. Ripoll noted this has been an ongoing item on the agenda.

Ms. Litwin had questions about landscape regarding the Willows and Laurels maintenance.

Mr. Chavez stated Willows and Laurels are paying for their landscape and maintenance. He noted he is waiting for LMP to provide conformation that it has been taken out of the CDD contract.

There was discussion about the grass cutting and irrigation.

The Board reviewed a map of the area.

Ms. Litwin asked about the light poles that the District owns that are part of the land the District sold.

District staff will follow up on the conveyance of the land back to the District from the Developer regarding the appraisal.

Mr. Chambers suggested Medallion give back the eastern part of the land where the gazebo is located.

Discussion ensued regarding the watering schedule.

On MOTION by Mr. Stolarz, seconded by Ms. Litwin, with all in favor, the Board approved changing the water schedule to 24 hours on Tuesday, 8:00 a.m. to 5:00 p.m. on Wednesdays, and Thursday, Saturday, and Sundays from 7:00 p.m. to 7:00 a.m.

Status of Davis Property Maintenance

Ms. Ripoll stated she will follow up with LMP on addendum and District Counsel will review the documents.

Discussion Pertaining to Addition of a Gym to the Amenities Center

This item was tabled.

Consideration of Fiscal Year 2023 Audit Engagement Letter

Ms. Ripoll stated this was reviewed by District Counsel and changes have been incorporated. She noted this is the engagement letter for the District to start the audit.

On MOTION by Ms. Litwin, seconded by Mr. Tokarz, with all in favor, the Board approved the Fiscal Year 2023 Audit Engagement Letter in the amount of \$4,085.00.

Review and Consideration of Loan Agreement and Promissory Note

Ms. Ripoll stated this item is regarding the Hoover pump.

Mr. Cohen stated he has incorporated his changes and comments in the version the Board is seeing today.

Discussion ensued regarding the funds being available by January 31, 2024.

On MOTION by Mr. Tokarz, seconded by Mr. Chambers, with all in favor, the Board accepted the Loan Agreement and Promissory Note.

Review and Consideration of Pond Maintenance Proposals

Ms. Ripoll stated the District received notice from Lake Doctors of an increase in their pricing. She noted the District currently has two proposals and waiting on the third.

The Board discussed the issues with the current vendor.

District staff will work with Counsel on getting the new contract.

Ratification of District Management Fee Agreement

Ms. Ripoll stated the District Management fee was increased.

On MOTION by Ms. Litwin, seconded by Mr. Chambers, with all in favor, the Board ratified the District Management Fee Agreement.

Ratification of Payment Authorization Nos. 219 - 224

Ms. Ripoll stated these are contractual and have been signed by the Chair.

On MOTION by Mr. Chambers, seconded by Ms. Beccia, with all in favor, the Board ratified payment authorization Nos. 219 - 224.

Review of District Financial Statements

The Board reviewed the financials.

THIRD ORDER OF BUSINESS

Other Business

Staff Reports

District Counsel- No report.

District Engineer- Not present.

District Manager- Ms. Ripoll stated the next meeting is November 28, 2023, at 11:00 a.m. at Holiday Inn Sarasota – Airport 8009 15th Stret East, Sarasota, FL, 34243.

Ms. Ripoll stated she has been working with Ms. Litwin in regard to the pool chairs.

On MOTION by Ms. Beccia, seconded by Mr. Tokarz, with all in favor, the Board approved a not-to-exceed amount of \$4,000.00 to purchase lounge chairs.

FOURTH ORDER OF BUSINESS

Supervisor Requests and Audience Comments

Ms. Litwin asked about the grill and fire pits functionality.

FIFTH ORDER OF BUSINESS

Adjournment

Ms. Ripoll requested a motion to adjourn the meeting.

On MOTION by Ms. Beccia, seconded by Mr. Chambers, with all in favor, the Board adjourned the October 24, 2023, Board of Supervisors' Meeting for Cross Creek Community Development District.

Secretary/Assistant Secretary

Chairperson/ Vice Chairperson

**Cross Creek
Community Development District**

Consideration of Resolution 2024-01, Election of
Officers

RESOLUTION 2024-01

A RESOLUTION OF THE BOARD OF SUPERVISORS OF THE CROSS CREEK COMMUNITY DEVELOPMENT DISTRICT ELECTING THE OFFICERS OF THE DISTRICT, AND PROVIDING FOR AN EFFECTIVE DATE

WHEREAS, the CROSS CREEK COMMUNITY DEVELOPMENT DISTRICT (hereinafter the “District”) is a local unit of special-purpose government created and existing pursuant to Chapter 190, Florida Statutes; and

WHEREAS, pursuant to Section 190.006(6), Florida Statutes, as soon as practicable after each election or appointment to the Board of Supervisors (the “Board”), the Board shall organize by electing one of its members as chair and by electing a secretary, and such other officers as the Board may deem necessary.

NOW, THEREFORE, BE IT RESOLVED BY THE BOARD OF SUPERVISORS OF THE CROSS CREEK COMMUNITY DEVELOPMENT DISTRICT:

Section 1. Charlie Tokarz is elected Chairperson.

Section 2. Connor Chambers is elected Vice Chairperson.

Section 3. Venessa Ripoll is elected Secretary.
Lianna Litwin is elected Assistant Secretary.
Bruce Stolarz is elected Assistant Secretary.
Kathy Beccia is elected Assistant Secretary.
Vivian Carvalho is elected Assistant Secretary.
Jorge Orsini is elected Assistant Secretary.

Section 4. Amanda Lane is elected Treasurer.

Section 5. Jennifer Glasgow is elected Assistant Treasurer.
Rick Montejano is elected Assistant Treasurer.
Verona Griffith is elected Assistant Treasurer.
Amy Champagne is elected Assistant Treasurer.

Section 6. All resolutions or parts of Resolutions in conflict herewith are hereby repealed to the extent of such conflict.

Section 7. This Resolution shall become effective immediately upon its adoption.

PASSED AND ADOPTED THIS ____ DAY of _____, 2024.

ATTEST:

**CROSS CREEK
COMMUNITY DEVELOPMENT
DISTRICT**

Secretary/Assistant Secretary

Chair/Vice Chair

**Cross Creek
Community Development District**

Consideration of Resolution 2024-02,
Designating Authorized Signatories for the
District's Bank Account(s)

RESOLUTION 2024-02

A RESOLUTION OF THE BOARD OF SUPERVISORS OF THE CROSS CREEK COMMUNITY DEVELOPMENT DISTRICT AUTHORIZING THE DISTRICT MANAGER TO DESIGNATE THE AUTHORIZED SIGNATORIES FOR THE DISTRICT'S OPERATING BANK ACCOUNT(S); AND PROVIDING FOR AN EFFECTIVE DATE.

WHEREAS, the Cross Creek Community Development District ("District") is a local unit of special-purpose government established pursuant to Chapter 190, Florida Statutes, and located in Manatee County, Florida; and

WHEREAS, the Board of Supervisors of the District ("Board") has previously established a checking account on behalf of the District; and

WHEREAS, pursuant to Chapter 190, *Florida Statutes*, the funds of the District shall be disbursed by warrant or check signed by the Treasurer and by such other person as may be authorized by the Board; and

WHEREAS, the Board has, pursuant to Resolution 2024-01, elected a Chair, Secretary, Treasurer and Assistant Treasurer(s) for the District; and

WHEREAS, the District Board desires to authorize signatories for the operating bank accounts(s).

NOW, THEREFORE, BE IT RESOLVED BY THE BOARD OF SUPERVISORS OF THE CROSS CREEK COMMUNITY DEVELOPMENT DISTRICT:

1. The Chair, Secretary, Treasurer and Assistant Treasurer(s) are hereby designated as authorized signatories for the operating bank account(s) of the District.
2. This Resolution shall take effect immediately upon its adoption.

PASSED AND ADOPTED this 23rd day of January 2024.

ATTEST:

**CROSS CREEK COMMUNITY
DEVELOPMENT DISTRICT**

Secretary/Assistant Secretary

Chair/Vice Chair

**Cross Creek
Community Development District**

Ratification of Advanced Aquatics Services, Inc.
Agreement

**AGREEMENT BY AND BETWEEN
CROSSCREEK COMMUNITY DEVELOPMENT DISTRICT
AND ADVANCED AQUATIC SERVICES, INC.**

THIS AGREEMENT (“Agreement”) is made and entered into this 1st day of December, 2023, by and between:

CrossCreek Community Development District, a local unit of special purpose government established pursuant to Chapter 190, Florida Statutes, being situated in Manatee County, Florida, and having offices at c/o PFM Group Consulting, LLC, 3501 Quadrangle Boulevard, Suite 270, Orlando, FL 32817 (the “District”); and

Advanced Aquatic Services, Inc., a Florida Profit Corporation (the “Contractor”), whose mailing address is 292 South Military Trail, Deerfield Beach, FL 33442 (the “Contractor”).

RECITALS

WHEREAS, the District is a local unit of special-purpose government, pursuant to and governed by Chapter 190, Florida Statutes, established for the purpose of financing, funding, planning, establishing, acquiring, constructing, or reconstructing, enlarging, or extending, equipping, operating, and maintaining systems and facilities for certain infrastructure improvements; and

WHEREAS, the District owns and has assumed responsibility for the managing and maintaining of certain waterways within the boundaries of the District; and

WHEREAS, the District desires to enter into an agreement with an independent contractor to provide specific services for these areas within the District; and

WHEREAS, the Contractor is a provider of such services and desires to contract with the District to do so in accordance with the terms and specifications in this Agreement; and

WHEREAS, the District and Contractor (collectively, “the Parties”) warrant and agree that they have all right, power, and authority to enter into and be bound by this Agreement.

NOW THEREFORE, in consideration of the recitals, agreements, and mutual covenants contained herein and other good and valuable consideration, the receipt and sufficiency of which are hereby acknowledged by the Parties, the Parties agree as follows:

1. INCORPORATION OF RECITALS. The recitals so stated are true and correct and by this reference are incorporated into and form a material part of this Agreement.

2. CONTRACTOR’S OBLIGATION.

A. **General Requirements.** Contractor shall, upon execution of this Agreement by both parties, manage twelve (12) ponds with a total shoreline of approximately 14,377 linear feet (as more specifically referenced in the Waterway Chart and map attached hereto as **Exhibit “A.”** On an annual basis, Contractor shall provide a minimum of eighteen (18)

Statutes, or other statute. Specifically, any covenant by the District to hold the Contractor harmless or similar provision is with the express understanding that such provision does not waive the sovereign immunity protections of the District and is only to the extent allowable by law. Nothing in this Agreement (including any exhibit) shall inure to the benefit of any third party for the purpose of allowing any claim which would otherwise be barred under the Doctrine of Sovereign Immunity or by operation of law.

10. NEGOTIATION AT ARM'S LENGTH. This Agreement has been negotiated fully between the parties as an arm's length transaction. The parties participated fully in the preparation of this Agreement and received the advice of counsel. In the case of a dispute concerning the interpretation of any provision of this Agreement, all parties are deemed to have drafted, chosen and selected the language and the doubtful language will not be interpreted or construed against any party.

11. ENFORCEMENT. A default by any party under this Agreement shall entitle the other parties to all remedies available at law or in equity which shall include, but not be limited to, the right of damages, injunctive relief, and specific performance.

12. TERMINATION. The District has the right to terminate this Agreement immediately for cause. Notwithstanding any other notice provisions referenced herein, the District further has the right to terminate this Agreement without cause and in its sole and absolute discretion and with the provision of thirty (30) days written notice. The Contractor has the right to terminate this Agreement for non-payment of non-disputed amounts more than sixty (60) days past due and further has the right to terminate this Agreement without cause and in its sole and absolute discretion and with the provision of ninety (90) days written notice to the District.

13. INDEPENDENT CONTRACTOR. The Parties agree that Contractor is and shall remain at all times an independent contractor and Contractor, its agents, and employees, shall not in any proceeding or in any other way claim or be considered an employee of the District.

14. ENTIRE AGREEMENT. This instrument shall constitute the final and complete expression of the agreement between the parties relating to the subject matter of this Agreement.

15. AMENDMENT. Amendments to and waivers of any provisions contained in this Agreement may be made only by an instrument in writing which is executed by all of the parties hereto.

16. AUTHORITY TO CONTRACT. The execution of this Agreement has been duly authorized by the appropriate body or official of all parties hereto, each party has complied with all the requirements of law and each party has full power and authority to comply with the terms and provisions of this instrument.

17. NOTICES. All notices, requests, consents, and other communications hereunder ("Notices") shall be in writing and shall be delivered, mailed by overnight delivery or First-Class Mail, postage prepaid, and e-mailed to the parties, as follows:

If to Contractor:

Advanced Aquatic Services, Inc.
292 S. Military Trail
Deerfield Bch, FL 33442
Attn: Jessica Lynn
e-mail: jessica@AdvancedAquatic.com

IN WITNESS WHEREOF, the parties hereto have signed and sealed this Agreement on the day and year first written above.

**CROSSCREEK
COMMUNITY DEVELOPMENT DISTRICT**

Jack Ozgun
Witness

Print Name: *Jack Ozgun*

Charles McKay
Chair, Board of Supervisors

ADVANCED AQUATIC SERVICES, INC.

Jessica Lynn
Witness

Print Name: *Jessica Lynn*

Jack R. Anderson
By: *Jack R. Anderson*
Its: *President*

Cross Creek Community Development District

Update on Conveying Land Back to CDD and
Getting More from the Developer Regarding
Appraisal

**Cross Creek
Community Development District**

Discussion of Barbeque Grill
Replacement/Repair

SUBER BAN PROPANE

6991 15th Street EAST
SARASOTA, FL 34243

941-753-0503 ALFRESCO

✓ MULLETS APPLIANCES

4233 CLARK ROAD SARASOTA, FL 34233
941-921-5531

DEALERS
LIST.

American Grill & Hearth - SARASOTA FL 941-925-3985

carry & install ALFRESCO GRILLS

2881 CLARK ROAD #16 SARASOTA 34231

X Backyard builds & move Ellenton FL 941-776-7517

3904 US 301 NORTH 34222

13 reviews 5.0 STARS

✓ OUTDOOR kitchen cabinets & move 5.0 STARS 227 reviews

11033 GATEWOOD DRIVE Lakewood Manor FL 34211

941-744-5000

X Manatee River kitchen & Bath

3704 H4 301 N Ellenton, FL 34222

941-479-4924

✓ Ferguson Enterprises SARASOTA

5521 Fruitville Road SARASOTA 34232

864-972-2921

✓ Troops Appliances

3756 Bee Ridge Road SARASOTA 34233

941-927-4900

~~done~~

VIDEOS

ALFresco GRILLS

AVAILABLE MODELS

\$8,139 BBQ boys

TWO TYPES of 56" GRILLS

① ALXE-56BFG
Does NOT have side
Burner AS NOTED Below
56" ~~Deluxe~~ ^{ALL} Grill

② ALXE-56
Deluxe Grill

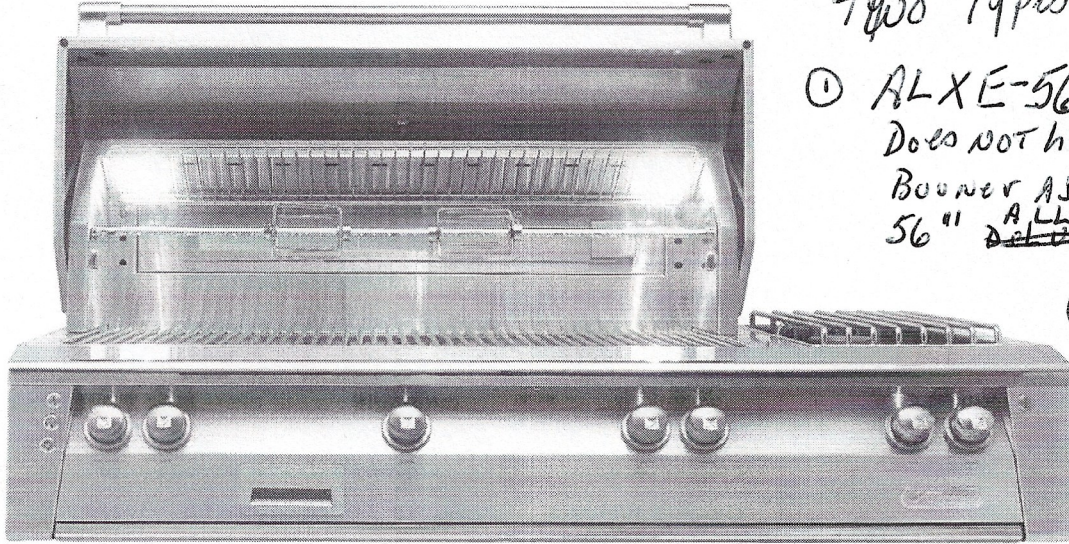

Deluxe Model ↑ Built-in Model

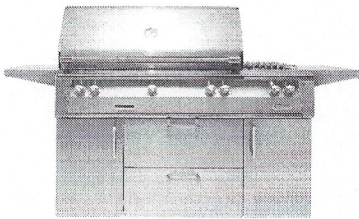

Standard Cart

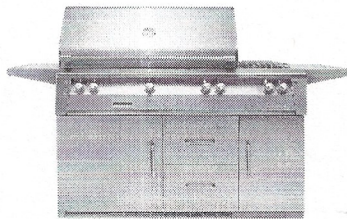

Refrigerated Cart

Make A Tasteful Impression

Adding unique real-smoke-flavors to your outdoor cooking is surprisingly simple.

Every Alfresco Grill comes equipped with our state-of-the-art

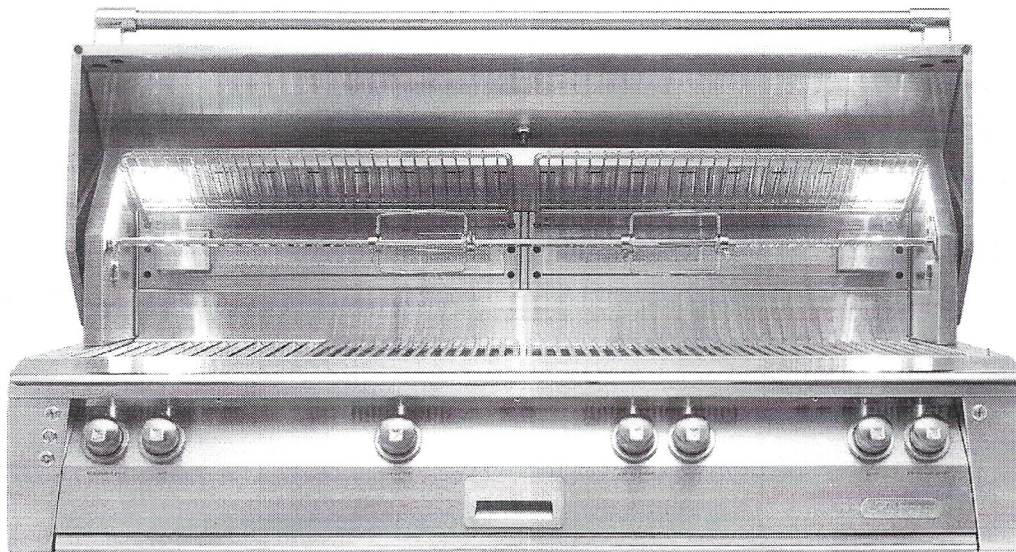

All Grill model [↑] Built-in Model

Make A Tasteful Impression

Adding unique real-smoke-flavors to your outdoor cooking is surprisingly simple.

Every Alfresco Grill comes equipped with our state-of-the-art SIGNATURE TASTE™ integrated smoking system, allowing for unparalleled originality.

From "smoketissing" to cold-smoke roasting, no other grill in the world offers more control, power, and versatility.

Alfresco ALXE Gas Grill Review

The Skinny:

- Restaurant inspired, top-notch quality
- Clean, polished look with LED lights
- Incredible performance and versatility
- Made in the USA

Things We Love:

The **Alfresco ALXE grill** is designed for the entertainer or culinarian who appreciates quality, versatility, performance and style.

Featuring true commercial-quality construction and performance, this restaurant-inspired grill is extremely versatile and made to cook. It all starts with their high 18-SR stainless steel high performance Accufire™ main burners, which are fully utilized due to the airtight construction of the grill's firebox, and the optional restaurant-quality infrared Sear Zone™ that sears around 1600°F.

Above the stainless steel burners sit the ceramic briquettes, which have concave backs for very even heat distribution, whether you're on low heat or high. The ceramic briquette trays also lock into place, and they can be flipped over for easy cleaning. For bonus flavor, take advantage of the Signature Taste™ integrated smoker system with dedicated burner and drawer for wood chunks. The smoker box works well with aromatics or liquids and rests under the ceramic briquettes, allowing the smoke to engulf your food for maximum flavor enhancement.

Standing further out from the competition is the motor of the Integrated Mega-Drive™ rotisserie system with infrared burner — on the Alfresco ALXE, it's completely built-in and hidden from sight. The chain-driven rotisserie can smoothly turn as much as 120 lbs. of prime rib, whole chickens, ribs, and much more.

With its polished stainless steel and amber LED lights above the knobs (that stay cool to the touch because of the innovative air-cooled front control panel), this American-made grill has a stand-out stylish appearance. From the spring lid assist with a 20-year high-heat lubricant to the versatile accessory options, this grill has everything you need for truly luxurious cooking.

You can be confident in Alfresco, which offers one of the best warranties in the industry, offering a lifetime warranty on the grills stainless steel components and burners, along with the Freedom Warranty which covers all parts and repairs for a full 2 years.

Feedback

Things To Consider:

While Alfresco's infrared Sear Zone™ produces an extreme amount of heat, it doesn't offer much of a low turn down when cooking food that requires a low temperature.

increased possibility of a flare up. when food drips through grill

You'll Like This Grill If:

You want a top-of-the-line commercial quality grill that is built to perform with the professional in mind.

Excellent	★★★★★	4.5
<u>Value</u>	★★★★☆	4.0
<u>Design & Style</u>	★★★★☆	4.5
<u>Construction</u>	★★★★★	5.0
<u>Innovation</u>	★★★★☆	4.5
<u>Even Heat</u>	★★★★☆	4.5
<u>High Heat</u>	★★★★★	5.0
<u>Minimum Flare-Ups</u>	★★★★☆	4.0
<u>Temperature Range</u>	★★★★☆	4.5
<u>Customer Service</u>	★★★★☆	4.0
<u>Warranty</u>	★★★★☆	4.5

Feedback

[View All Gas Grill Reviews >](#)

Shop All Alfresco ALXE Gas Grills

Customers Also Viewed

OVERVIEW

KEY FEATURES

SUPPORT

COMMUNITY

REVIEWS

JUMP TO SECTION

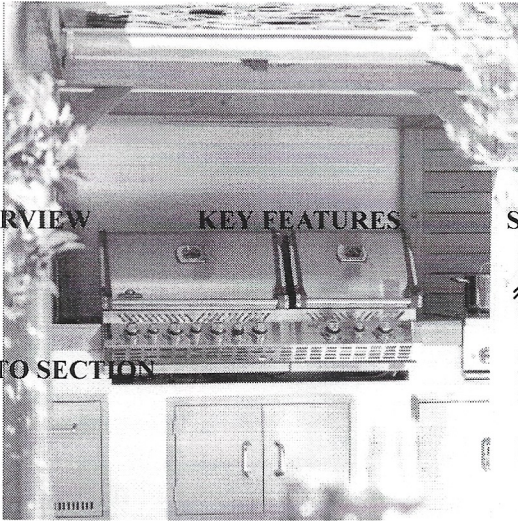

YOU MAY ALSO LIKE

NAPOLEON Prestige Pro Grill

PREVIOUSLY VIEWED

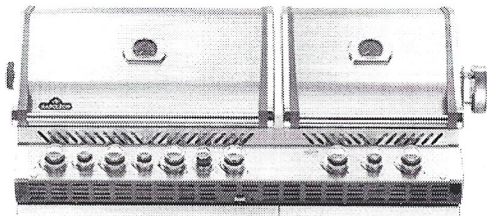

Built-in Prestige PRO™ 825 RBI
with Infrared Bottom and Rear Burners
\$4,499 USD

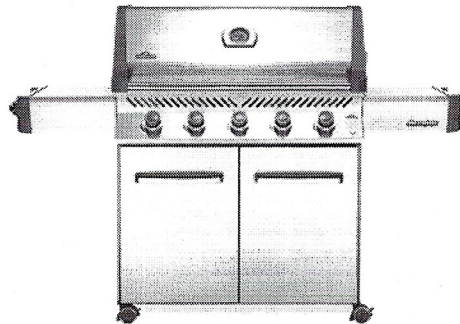

Prestige® 665
Gas Grill
\$2,049 USD

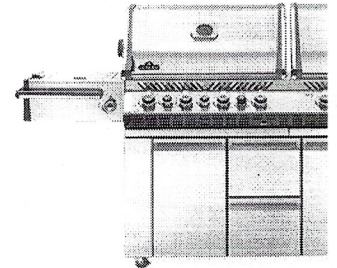

Prestige PRO™ 825
with Power Side Burner, In
Bottom Burner
\$4,999 USD

*INFRARED HEATING
MADE IN CANADA
PROP 65 WARNING*

REVIEWS

Reviews



Rating Snapshot

*I Believe they also have a one piece
48" grill as opposed to a two section grill.*

Napoleon Prestige Pro Review

The Skinny:

- Well-known brand name
- Fully loaded with great features
- Proudly made in North America
- Great Warranty

Things We Love:

The **Napoleon Prestige Pro** is a feature packed gas grill with innovative accessories and integrated functionality. The Prestige Pro series comes with an infrared rear burner, rotisserie, and “sizzle zone” infrared burner. **Freestanding Prestige Pro** models also include an ice bucket with integrated cutting board. You can also add the optional **charcoal tray** for even more ways to cook. The grill comes with LED Spectrum Night Light control knobs with color customizable lights. The lights have a safety glow feature that make them glow red when a burner is in use. The Prestige Pro series also has interior grill lighting for night time grilling and lighting in the storage area under the grill. I also really like Napoleon’s doubled lined “lift-ease” lid, which opens easily and helps hold in heat for optimal heat retention. The lid is hinged near the middle and, when open, adds hardly any depth to the back of the grill. This allows for easy placement in a variety of spaces. The **Pro 825** has two “sizzle zone” burners in the second grill area, and a two stage power burners on the side shelf.

Feedback

One thing that really sets the Prestige Pro apart is its storage features. The Pro boasts soft close storage doors, built-in shelving in the cabinet, condiment racks, tool hooks, towel bars, and even a bottle opener with cap catcher.

Napoleon Prestige Pro grills have stainless steel tube burners that are lit by a "Jetfire" electronic ignition. The Pro series has stainless steel grates with a patented wave design that creates unique sear marks. To spread heat evenly, Napoleon has stainless steel sear plates. The plates also protect the burners and help reduce flare-ups.

The Prestige Pro grills are also available as **built-in models**, a perfect fit for any outdoor kitchen.

The warranty on the Prestige Pro series is a standout in its class, having a lifetime warranty on the exterior housing, cooking grids, and stainless steel cooking box. Napoleon also boasts a 10 year + 5 warranty on their burners and flame tamers that provides replacement parts at a 50% of normal cost for 5 years after the 10 year warranty expires.

Thing To Consider:

While this grill is built tough, and backed by a strong warranty, Napoleon Prestige Pro grills are not "all stainless steel", which is what many customers are shopping for nowadays. Along with the stainless steel components on the grill, you will also find cast aluminum and porcelain enameled steel components too, such as cart legs, back panels, etc.

Excellent	★ ★ ★ ★ ☆	4.1
<u>Value</u>	★ ★ ★ ★ ☆	4.0
<u>Design & Style</u>	★ ★ ★ ★ ★	5.0
<u>Construction</u>	★ ★ ★ ★ ☆	4.0
<u>Innovation</u>	★ ★ ★ ★ ☆	4.5
<u>Even Heat</u>	★ ★ ★ ★ ☆	4.0
<u>High Heat</u>	★ ★ ★ ★ ☆	4.0
<u>Minimum Flare-Ups</u>	★ ★ ★ ★ ☆	4.0
<u>Temperature Range</u>	★ ★ ★ ★ ☆	3.5
<u>Customer Service</u>	★ ★ ★ ★ ☆	3.5
<u>Warranty</u>	★ ★ ★ ★ ☆	4.0

Feedback

[View All Gas Grill Reviews >](#)

Shop All Napoleon Prestige Pro Grills

Customers Also Viewed

Built-in Grills

IBI30,36,42,48

052021

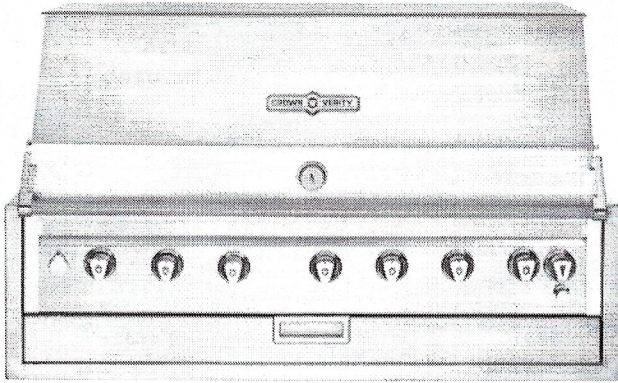

IBI48

*w/ost light package & 6,416-
w/ Specifications
light package & 7,380-*

- Gas grill constructed of 304 stainless steel including grids, burners and all fasteners
- 14,750 BTUH straight tube burner *4.7 STARS*
- Ready to use: ships completely assembled and comes with an insert shell ready to drop into an island
- Includes water/grease tray with deflector and drain port to ease cleaning and reduce flare-ups
- 16 gauge stainless steel radiants that remain in place during transportation and cleaning
- Stainless steel pilot burner tube system with built-in ignition system
- Lift assist technology, making domes easy to open and close

More Standard Features

- Unibody design for lighter weight and added strength
- Regulator for NG & LP models
- Factory technician tested prior to shipping
- Limited lifetime warranty.
- 1 year parts and labor limited warranty
- Refer to manual and warranty for residential and commercial usages.

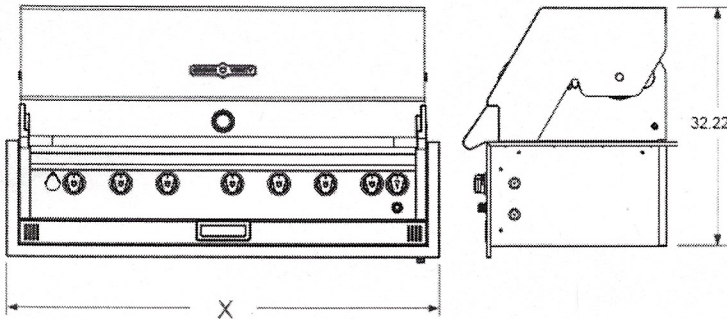

	IBI30	IBI36	IBI42	IBI48
X	35.34	41.34	47.34	55.723

Options/Accessories

- Griddle Plate (CV-SP1423)
- Rotisserie (CV-RTXX-BI)
- Smoker Box (CV-SBK)
- Charcoal Tray (CV-CTP)
- Light Packages (XXFDLT/FLT/DLT)

Built in Island Accessories

*Available empty, 1, 2 and 3 drawer versions

- 3 Drawer Compartment (IBILC-3D)*
- Propane Compartment (IBILC-PH)
- Ice Chest (CV-ICI)
- Vertical Access Door (IBI-VD)
- Horizontal Access Door (IBIXX-HD)
- Side Burner with cabinet (IBISC-SB)
- 2 Drawer Compartment (IBISC-2D)*
- Trash Compartment (IBILC-GH)
- Horizontal Drawer (IBIXX-DD)
- Outdoor Fridge (CV-RF-1)

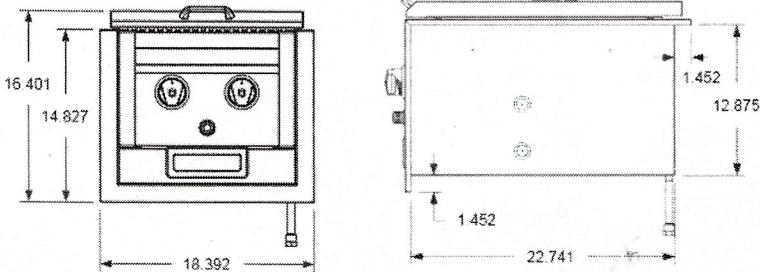

Prof 63 warranty

Certifications



Specifications

All above shown with options

052021

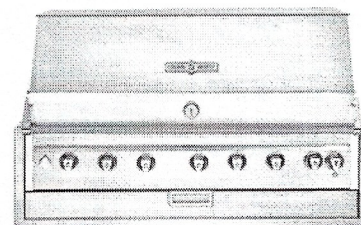
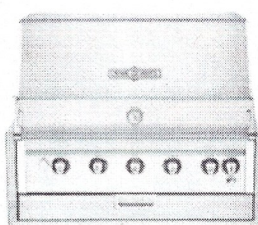

Model	IB130	IB136	IB142
Number of Burners	4	5	6
BTUH	64,500	79,250	94,000
Actual Weight (lbs)	131	163	131
Shipping Weight (lbs)	209	243	209
Cooking Surface	28" x 21"	34" x 21"	40" x 21"
Overall Dimensions	35.34" W x 32.22" H x 24.693" D	41.34" W x 32.22" H x 24.693" D	47.34" W x 32.22" H x 24.693" D
Cut Out Dimensions	33" W x 13" H x 23 D"	39" W x 13" H x 23 D"	45" W x 12" H x 23 D"

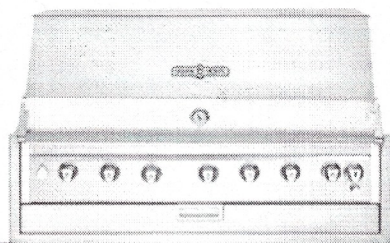

OR

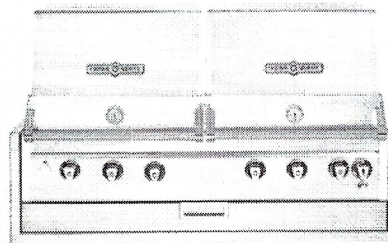

Model	IB148	IB1482RD
Number of Burners	7	6
BTUH	108,750	94,000
Actual Weight (lbs)	194	194
Shipping Weight (lbs)	284	284
Cooking Surface	46" x 21"	two 22" x 21"
Overall Dimensions	55.723" W x 32.22" H x 24.693" D	55.723" W x 32.22" H x 24.693" D
Cut Out Dimensions	53.375" W x 12" H x 23 D"	53.375" W x 12" H x 23 D"

Optional side burner (IB1SB) - A side burner increases flexibility, providing a convenient surface for sauteing and keeping sauces hot.

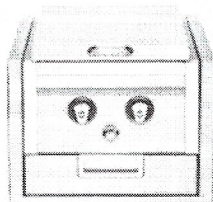

IB1SB

Model	IB1SB
Number of Burners	2
BTUH	24,000
Weight (lbs)	30
Overall Dimensions	18.392"W x 24.693"D x 16.401"H
Cut Out Dimensions	16"W x 23"D x 13.125"H

**Cross Creek
Community Development District**

Review and Consideration of Pool Resurfacing
Proposal



155 West Dearborn Street • Englewood, FL 34223 • Phone: 9414973333

Cross Creek
Phone: 407-723-5943
Cell: +12679907193

Job Address:
4000 Creekside Park Dr
Parrish, FL 34219

Print Date: 1-16-2024

Proposal for Cross Creek

Pool Surface Preparation Specifications:

- De-Chlorinate and Drain Pool
- Acid Wash & Neutralize Pool
- Remove Delamination of Old Surface (includes up to 10% of existing finish)
- Chip Around Returns & Lights
- Remove any Loose Surface Material from the Pool
- Prepare Swimming Pool Surface with Quality Bond Kote
- Replace Return Fittings and Main Drain Cover

Pool Resurface Material: (Select One Below)

- The pool will be resurfaced with material of your choice, warranties as stated below.
- Prices vary based on surface material and color choice. (See color group lists in the folder for reference)
- Once the pool has been resurfaced and re-filled, We will begin After-care to balance the pool water.
- After-care will be until the pool is properly balanced. (See After-Care Instructions Sheet in Folder for additional info)

Material, Color, Price

- Lifetime limited warranty on surface material, unless otherwise specified.
- All well water residents require water trucks.
- If the customer declines leak detection, Aqua Doc Pool Clinic shall not be held liable in the event of a pool or spa leak
- Pool must be clear and full. Leak detection is: Pressurize plumbing, check light, skimmer, returns, water line tile and anything that looks suspicious on the pool surface.

Items	Description	Cost Type	Price
Stonescapes Group 1 Regular Pebbles: Aqua Cool Stonescapes Group 1		Material	\$80,995.00
Gutter Surface Stonescapes Group 1			\$3,700.00
Water Trucks Water Trucks Reno	*All well water residents require water trucks. Failure to sign up for water trucks, Aqua Doc Pool Clinic shall not be held liable in the event of pool or spa staining. If the total price is \$0, Water trucks have been declined.	Labor	\$0.00
Leak Detection Leak detection Pool Reno	*If the customer declines leak detection, Aqua Doc Pool Clinic shall not be held liable in the event of a pool or spa leak. The pool must be clear and full. If the total price is \$0, Leak detection has been declined.	Labor	\$1,850.00

Tile

- If you plan to keep your existing tile, we will undercut the waterline tile in the preparation process.
- If the existing tile is being replaced, we will remove all tiles before installing the new tile in the preparation process.
- All step tiles, bench tiles, decorative items, and mosaics will be removed in the preparation process and is optional to replace them with new ones at an additional cost.
- No step or bench tile will be installed unless otherwise indicated.
- Tile grout is white unless otherwise specified.

Items	Description	Cost Type	Price
Install Waterline Tile (6x6) Waterline Tile Reno	Grout: White	Material	\$8,215.00
Install Top Tile (2x6 Non-skid) around gutter 2x6 Tile Reno	Grout: White		\$8,370.00
Step & Bench Tile (2x6 bullnose Non-skid) Step Tile Reno	Grout: White	Material	\$2,325.00
Depth Marker Tiles Marker Tile			\$1,000.00
(2) Swim Lane Tile Markers Marker Tile			\$4,960.00
Belly Band belly band tile			\$1,240.00
(3) Main Drains 12x12 Main Drain			\$450.00
(26) Gutter Grates Misc.			\$365.00
(10) Circle Grates Misc.			\$150.00
Permits Permitting for Reno			\$1,000.00

Draw Schedule - Payments must be made to Aqua Doc Pool Clinic by ACH or Credit card. Credit Card payment will incur a 3% fee.

35% Deposit due upon signing proposal	1st Deposit	\$40,117
45% Deposit due upon draining the pool	2nd Deposit	\$51,579
20% Balance Due before Plastering	Balance	\$22,924
Total Contract Amount	Total	\$114,620

Total Price: \$114,620.00

- 1. Ownership: The purchaser warrants that he/she owns the land upon which the work is to be performed.**
- 2. Material Selection: The owner is solely responsible for the material and color selection of all products utilized by the Contractor and agrees to ensure that all such selections meet or exceed any neighborhood, city, homeowner's association, or any other requirements. Owner shall indemnify and hold Contractor harmless from any action brought by any person, group, or entity concerning the type, color, or other characteristic of the material selected by Owner. Commercial Pools are limited to their material selections based on County Health Department Codes. The contractor will advise which materials are acceptable to current codes. It is understood that THERE ARE NO OTHER UNDERSTANDINGS, PROMISES, OR AGREEMENTS THAT EXIST THAT ARE NOT REPRESENTED IN THIS AGREEMENT. NO VERBAL AGREEMENTS ARE VALID unless put forth in writing herein.**

3. **Work Site:** The owner is responsible for work being done within property lines in conformity with local zoning laws, the pool site shall be clear of easements and set back restrictions and the Contractor shall be held harmless from liability to the Owner or a third person from such work beyond said property lines. Owner shall guarantee that Contractor shall have reasonable access to the contract property and that property shall not be encumbered or sold while under contract. The contractor is not responsible for dust, at a construction site, dust will occur. For non-deck projects, we recommend covering (which may deter, but not eliminate dust altogether) or removing furniture if desired. For deck projects, furniture will need to be removed before the start of the project, by the homeowner. The homeowners will be responsible for damaging personal items such as lawn furniture or portable plants left etc. in the construction areas. Moving of furniture, plants, etc. from decks and construction areas will be billed separately. We recommend homeowners clean windows, doors, etc. after the project is complete. Noise may occur during the project.
4. **Work Site Clean-up:** The contractor shall provide clean-up within the aftercare for pool projects. Deck-only projects may need multiple visits after the project. Clean-up consists of removing all material brought on-site for the project. There may be a rinse or pressure wash of the deck for deck jobs, and a rinse of the deck for pool-only jobs may be done within the aftercare. The first few visits of aftercare are normally for chemical balancing only. Dump & material disposal fees will be billed at cost (if applicable) to the homeowner and are not included in the price.
5. **Acknowledgment of Work:** Contractor shall not be responsible for damage to any part of the contract property, pool, pool cage, or dwelling resulting from natural causes, weather, or an act of God, including earthquakes, hurricanes, ground swells, landslides or any natural or accidental cause from rain, hail, storms or floods. The contractor shall not be responsible for damages or delay caused by other persons (including other Subcontractors) working on contract property. The contractor is also not responsible for grass damage during the project from material placement during the project or work being done. No sod replacement, reseeding, or replacement of shrubs and landscaping material shall be provided by the contractor unless specifically spelled out in this agreement. The homeowner acknowledges that the contractor/crew could be on the property for approximately 4-6 weeks if no unforeseen circumstances occur.
6. **Utilities:** The owner ensures necessary electricity, water, and other utilities during remodeling and to operate the pool, The Purchaser agrees to furnish water, and electrical power, at his/her expense, including the initial filling of the pool, needed to complete the terms of this contract and that they accept responsibility for any damage to the pool or any part thereof, as result of any construction which is performed on or around the contract property by anyone other than Contractor. The Owner warrants that there will be no underground obstruction, such as electric lines, or any other such item which would require removal or relocation in order to complete the proposed contract work. In such event, the Owner agrees to pay all costs incurred by the Contractor for removal or relocation of such obstructions, plus 20% of such costs, within five (5) days after completion of any work necessitated under the terms of this contract. The contractor may need assistance from the homeowner regarding electrical issues to ensure the project is not delayed.
7. **Stoppage:** The contractor reserves the right to stop work at any time until past due payments according to the terms of the contract are brought up to date. The contractor shall not be responsible or liable for any damages caused by the Owner's delay. The owner agrees any such work stoppage shall not be grounds for breach of contract. Payments are due at the start of each applicable phase of work that is being performed and the Owner agrees to pay 1.5% interest per month from the date payment is due until payment is made if past due. The owner is responsible for any legal interests and reasonable attorney's fees if necessary. In the event the Owner fails to perform according to the terms of the contract or prevent the performance of the contract by the Contractor, the Owner shall be liable to the Contractor for all money actually expended by the Contractor in reliance upon this agreement. If the agreement is terminated by the Owner prior to the start of the work according to the contract, the Contractor shall retain any and all of the deposit money paid as liquidated damages. Payments must be made on schedule or work will stop until such payments are made. Late payments will void any free items or credits included in this contract. Purchaser agrees to pay all costs incurred because of non-payment or other breach of contract by the Purchaser including interest and fees for litigation. Work will be re-scheduled upon payment and

existing completion dates will be adjusted accordingly. Should the customer cancel this agreement after the commencement of work, the contractor reserves the right to a 30% cancellation fee plus payment for stages of work that have been completed

8. **Work Completed:** Work under this contract is deemed complete when the contractor's materials are installed. Buyer agrees that there are no warranties in effect and final inspections will not be called in until the contract is paid in full and that buyer will be responsible and liable for any damages that may occur for not adhering to the terms and conditions of this contract or delays. The contractor shall not be liable under any circumstances for incidental or consequential damages, and no claim for damages shall be greater in amount than the price of this contract. It is common for minor punchout items and final clean-up to extend beyond the time a final draw is due. A maximum of a \$200 holdback will be allowed without penalty for late payment. No free or specially priced items will be installed unless all invoices have been paid in full and on time. Draws are due the morning work is to be completed for designated stages. If full payment is not onsite the morning of completion, work shall not be completed and a \$500 trip charge will be billed to the homeowner and future draws will be paid in advance. This or any late payment will void any credits, special discounts, or free items included in this contract.
9. **Equipment Ownership:** Title and ownership of equipment and accessories described on the contract whether affixed to contract property shall remain the property of the Contractor until the total payment, according to the terms of the agreement, has been paid in full. The Owner agrees that if the amount is not paid in accordance with the terms of the agreement, the Contractor may, without notice, enter the premises and repossess said equipment and accessories, and that said entry shall not constitute a breach of the agreement. The contractor will apply the reasonable value of said equipment and accessories against the unpaid balance. If repossession is affected through legal process, the Owner will have such rights and liabilities as may be accorded under the State laws of Florida.
10. **Equipment:** The contractor shall not be held responsible for preexisting conditions not covered in this agreement for correction, including, but not limited to inadequate filtration equipment, underwater lighting, water leaks, and cleaning systems heads. If performing a skimmer replacement, the Skimmer will not be filled in until confirmed no leaks are present. The contractor will fill in the skimmer prior to the completion of the project.
11. **Product Changes:** All changes or additions to this contract shall be authorized by a signed addendum executed by the Purchaser and the Contractor. Charges for such items shall become due when billed and paid for before the existing construction schedule continues. Any product Changes to this agreement can be made at the discretion of Aqua Doc Pool Clinic. Change forms are subject to a \$100 fee.
12. **After-Care:** Before beginning aftercare, the Homeowner is responsible for watching the filling of the pool and shutting the hose off once the pool has reached normal operating level. The contractor will perform after-care until the pool chemicals are balanced depending on the resurfacing product unless otherwise stipulated. After-care is a free chemical service only and is not to be considered a pool cleaning service. The contractor will supply the preferred water chemistry condition document upon final payment for the Owner and/or Owner's pool technician's reference. Note: Commercial Properties that are serviced by Aqua Doc Pool Clinic will continue to have regularly scheduled tech service along with the after-care service.
13. **Warranty:** Cementitious pool interior finishes are semi-permeable membranes that allow small amounts of moisture to permeate through and into the substrate, over time. The finish will not debond or delaminate provided that the pool remains filled with water, is structurally sound, and the water chemistry after the start-up and after-care is properly maintained in accordance with Warranty guidelines. Water chemistry consists of chlorine levels, total alkalinity, pH, hardness (calcium & magnesium), stabilizer levers, copper, and total dissolved solids (TDS). All equipment and accessories furnished by the Contractor will remain the property of the Contractor and no warranty will be honored until all invoiced payments have been made. Failure to make such payments as invoiced will be considered a breach of contract and under this breach of contract, the Contractor has the right to remove the furnished pool equipment and/or accessories even if they are attached to real estate. Outstanding balances on items completed beyond 30 days shall permanently void all warranties & guarantees. Purchaser's failure to make full payment to contractor according to this contract and work orders shall void this warranty.

14. **Finishes:** Pool finishes are composed of materials that may have inherent shading and/or color variation that is normal and should not be construed as a defect. Environmental factors like humidity and temperature during the installation process, and normal color variation within a surface coating, called mottling, may appear. This condition is beyond the Contractor's control. Discoloration or shade variation is not considered a defect due to aggregate finishes having variations in the surface density, or variations in the concentration of aggregate across the finished surface. The owner agrees that the pool interior finish is not guaranteed for evenness of color and may not be the exact shade anticipated. Shade and color may vary and fade over time. The owner understands that hairline cracks may be noticeable and may be quite pronounced with color finishes. Staining of new surfaces from old, rusted lights, ladders, returns, or other items is the responsibility of the homeowner. Imperfections, such as Marcite and deck discoloration, hairline cracks in pool, and tile, and expansion cracks in decks and tile, which are inherent to this type of construction are not warranted. Etching, pitting, and scaling of the interior pool finish are caused by improper water chemistry and will not be warranted. Interior finishes are warranted only in areas where the material touches. Other areas such as plumbing, skimmers, main drains, and light niches, unless contracted separately, are not warranted.

**Cross Creek
Community Development District**

Discussion Pertaining to Addition of a Gym to
the Amenities Center

**Cross Creek
Community Development District**

Ratification of Payment Authorizations 225 - 234

CROSS CREEK COMMUNITY DEVELOPMENT DISTRICT

RECEIVED
OCT 13 2023

RECEIVED
OCT 03 2023

Payment Authorization No. 225

9/28/2023

Item No.	Vendor	Invoice Number	General Fund FY 2023	General Fund FY 2024
1	Landscape Maintenance Professionals Landscape Maintenance: October 2023	178743		\$ 14,245.00
2	PFM Group Consulting LLC Disclosure Fee S2007AB/S2016AB: 07/01/23-09/30/23	126947	\$ 1,000.00 ✓	
Subtotal			\$ 1,000.00	\$ 14,245.00
TOTAL				\$15,245.00

APPROVED. *COVINEZ* 10/11/23

Vivian Carvalho

Charles D. Payne, Chairman
Board Member

10/16/23

10/13/23

**CROSS CREEK
COMMUNITY DEVELOPMENT DISTRICT**

RECEIVED
OCT 12 2023

Payment Authorization No. 226
10/6/2023

Item No.	Vendor	Invoice Number	General Fund FY 2023	General Fund FY 2024
1	Bellmore Electric Pool Pump Electrical Repairs	8299		\$ 740.00 ✓
2	Cbert Trucking and Grading Irrigation Maintenance: October 2022-August 2023	82305	\$ 4,275.00 ✓	
3	Envera Clubhouse Alarm Monitoring: November 2023	733248		\$ 675.28 ✓
4	McClatchy Company Legal Advertising on 09/27/23 (Ad: IPL0140807)	214838	\$ 74.88 ✓	
5	Peace River Electric (paid online) 12220 SILKWOOD WAY; 08/10/23-09/10/23 4601 CREEKSIDE PARK DR; 08/10/23-09/10/23 4100 CREEKSIDE PARK DR; 08/24/23-09/23/23 4890 GOLF COURSE RD; 08/25/23-09/25/23 02-040-4L-1; 08/24/23-09/23/23 12407 LARCHMERE LN; 08/19/23-09/19/23 12400 SILKWOOD WAY; 08/10/23-09/10/23 12310 SILKWOOD WAY; 08/19/23-09/19/23	Acct:158231001 Acct:158231002 Acct:158231004 Acct:158231005 Acct:158231006 Acct:158231007 Acct:158231008 Acct:158231009	\$ 80.39 ✓ \$ 51.89 ✓ \$ 1,757.61 ✓ \$ 61.17 ✓ \$ 1,032.99 ✓ \$ 39.46 ✓ \$ 40.71 ✓ \$ 35.44 ✓	
6	Persson, Cohen, Mooney, Fernandez & Jackson District Counsel: September 2023	4167	\$ 560.00 ✓	
7	Southwest Maintenance Services Cleaning Services: October 2023	9056		\$ 480.00 ✓
8	Starner Pools Pool Maintenance: October 2023	28689		\$ 1,100.00 ✓

AP 10/11/23

Subtotal \$ 8,009.54 \$ 2,995.28

TOTAL \$11,004.82

APPROVED: *comavez* 10/13/23

Venessa Ripoll

Charlotta Ray, Chairman
Board Member

10/12/23

**CROSS CREEK
COMMUNITY DEVELOPMENT DISTRICT**

RECEIVED
OCT 17 2023

Payment Authorization No. 227
10/13/2023

Item No.	Vendor	Invoice Number	General Fund FY 2023	General Fund FY 2024
1	The Lake Doctors Herbicide Treatment on 10/09/23	1838497		\$ 1,800.00 ✓
2	Manatee County Utilities (paid online) 4000 CREEKSIDE PARK DR; 08/18/23-09/21/23 12501 RYEGRASS LOOP; 08/18/23-09/21/23 12515 FRESHWATER RUN; 08/21/23-09/21/23	Acct: 187908-133094 Acct: 187908-134766 Acct: 187908-134768	\$ 1,032.64 ✓ CREDIT CREDIT	
3	Peace River Electric (paid online) 3693 CREEKSIDE PARK DR; 09/04/23-10/05/23	Acct: 186140001	\$ 283.65 ✓	
4	Turner Pest Control Quarterly Pest Prevention Rodent Prevention	617855933 617857269		\$ 140.00 ✓ \$ 80.00 ✓

Subtotal \$ 1,316.29 \$ 2,020.00

TOTAL \$3,336.29

APPROVED: C. Chavez 10/20/23

Vivian Carvalho

Charles P. Key
Board Member

M
10/25/23

C
10/23/23

**CROSS CREEK
COMMUNITY DEVELOPMENT DISTRICT**

RECEIVED
NOV 02 2023

Payment Authorization No. 228
10/27/2023

Item No.	Vendor	Invoice Number	General Fund FY 2023	General Fund FY 2024
1	Department of Economic Opportunity FY 2024 Special District Fee	88890		✓ \$ 175.00
2	Frankie's Tree Service Tree Stump Grinding	--		✓ \$ 450.00
3	Landscape Maintenance Professionals Landscape Maintenance: November 2023	179479		✓ \$ 14,245.00
4	McGhee Electric Electrical Repairs	1012	\$ 1,892.00	✓
5	PFM Group Consulting LLC Tax Roll Preparation and Submission FY 2024	127510		✓ \$ 5,000.00
	District Management Fee: October 2023	DM-10-2023-14		✓ \$ 2,750.00
	FedEx: September 2022	OE-EXP-10-2023-14	\$ 10.41	✓
6	S&S Electric Well Pump Electrical Repairs	233268		✓ \$ 750.00
7	VenturesIn.com, Inc. Website Maintenance: October 2023	46569		✓ \$ 80.00

Subtotal \$ 1,902.41 \$ 23,450.00

TOTAL \$25,352.41

APPROVED: *Cebalvarez* 11/03/23

Venessa Ripoll

Charles Phay, Chairman
Board Member

OP 11/6/23

**CROSS CREEK
COMMUNITY DEVELOPMENT DISTRICT**

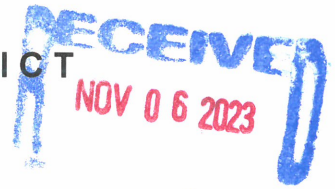

Payment Authorization No. 229
11/2/2023

Item No.	Vendor	Invoice Number	General Fund FY 2023	General Fund FY 2024
1	Envera Clubhouse Alarm Monitoring: December 2023	734319		\$ 675.28 ✓
2	Peace River Electric (paid online) 12220 SILKWOOD WAY; 09/10/23-10/10/23 4601 CREEKSIDE PARK DR; 09/10/23-10/10/23 4100 CREEKSIDE PARK DR; 09/23/23-10/24/23 4890 GOLF COURSE RD; 09/25/23-10/26/23 02-040-4L-1; 09/23/23-10/24/23 12407 LARCHMERE LN; 09/19/23-10/20/23 12400 SILKWOOD WAY; 09/10/23-10/10/23 12310 SILKWOOD WAY; 09/19/23-10/20/23	Acct:158231001 Acct:158231002 Acct:158231004 Acct:158231005 Acct:158231006 Acct:158231007 Acct:158231008 Acct:158231009		\$ 149.93 ✓ \$ 62.46 ✓ \$ 1,526.45 ✓ \$ 62.03 ✓ \$ 857.17 ✓ \$ 40.13 ✓ \$ 51.01 ✓ \$ 35.66 ✓
3	Persson, Cohen, Mooney, Fernandez & Jackson District Counsel: October 2023	4300		\$ 1,396.50 ✓
4	Southwest Maintenance Services Cleaning Services: November 2023	9141		\$ 480.00 ✓
5	Starner Pools Pool Maintenance: November 2023	28733		\$ 1,100.00 ✓
6	VenturesIn.com, Inc. Website Maintenance: November 2023	46615		\$ 80.00 ✓

Subtotal \$ - \$ 6,516.62

TOTAL \$6,516.62

APPROVED: C. Alvarez 12/07/23

Vivian Carvalho

Charles D. P... Chairman

Board Member

AD 12/10/23

**CROSS CREEK
COMMUNITY DEVELOPMENT DISTRICT**

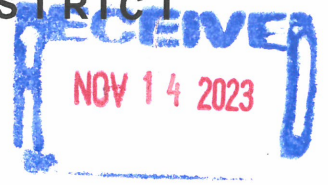

Payment Authorization No. 230
11/9/2023

Item No.	Vendor	Invoice Number	General Fund FY 2023	General Fund FY 2024
1	The Lake Doctors Herbicide Treatment on 11/03/23	1841509		✓ \$ 1,170.00
2	Manatee County Utilities (paid online) 4000 CREEKSIDE PARK DR; 09/21/23-10/17/23 12501 RYEGRASS LOOP; 09/21/23-10/17/23 12515 FRESHWATER RUN; 09/21/23-10/19/23	Acct: 187908-133094 Acct: 187908-134766 Acct: 187908-134768		✓ \$ 808.00 CRED CRED
Subtotal			\$ -	\$ 1,978.00

TOTAL \$1,978.72

APPROVED. @dmv 12/10/23

Vivian Carvalho

Charles Okey
Board Member

OK
12/15/23
12/16/23

**CROSS CREEK
COMMUNITY DEVELOPMENT DISTRICT**

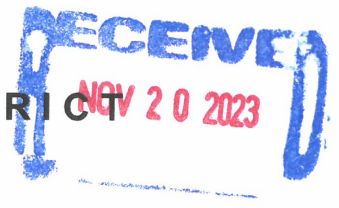

Payment Authorization No. 231
11/16/2023

Item No.	Vendor	Invoice Number	General Fund FY 2024
1	Peace River Electric (paid online) 3693 CREEKSIDE PARK DR; 10/05/23-11/05/23	Acct: 186140001	\$ 278.54 ✓
2	PFM Group Consulting LLC Billable Expenses: November 2023 District Management Fee: November 2023	127925 DM-11-2023-14	\$ 4,649.64 ✓ \$ 2,750.00 ✓
3	Starner Pools Splash Pad Motor Replacement Slide Valve Repair	28782 28783	\$ 2,676.50 ✓ \$ 457.00 ✓

TOTAL	\$ 10,811.68
--------------	---------------------

Approved: *cdmuez 12/01/23*

Vivian Carvalho

Charles P. King, Chairman
Board Member

OK
DM
12/16/23

**CROSS CREEK
COMMUNITY DEVELOPMENT DISTRICT**



Payment Authorization No. 232

11/30/2023

Item No.	Vendor	Invoice Number	General Fund FY 2024
1	Advanced Aquatic Services Initial Treatment / Lake Maintenance: December 2023	10551868	\$ 2,975.00 ✓
2	Egis Insurance Advisors, LLC FY 2024 Insurance - Volunteer & Board Member	20637	\$ 850.00 ✓
3	Landscape Maintenance Professionals Irrigation Control Valve Replacement Landscape Maintenance: December 2023	180037 180105	\$ 621.42 ✓ \$ 14,245.00 ✓

TOTAL

\$ 18,691.42

APPROVED: *C. Alvarez* 12/07/23

Vivian Carvalho

Charles P. ...
Board Member

*over
M
12/18/23*

CROSS CREEK COMMUNITY DEVELOPMENT DISTRICT

Payment Authorization No. 233
12/8/2023

Item No.	Vendor	Invoice Number	General Fund FY 2024
1	Envera Clubhouse Alarm Monitoring: January 2024	735432	\$ 675.28 ✓
2	Peace River Electric (paid online) 12220 SILKWOOD WAY; 10/10/23-11/10/23 4601 CREEKSIDE PARK DR; 10/10/23-11/10/23 4100 CREEKSIDE PARK DR; 10/24/23-11/24/23 4890 GOLF COURSE RD; 10/26/23-11/26/23 02-040-4L-1; 10/24/23-11/24/23 12407 LARCHMERE LN; 10/20/23-11/20/23 12400 SILKWOOD WAY; 10/10/23-11/10/23 12310 SILKWOOD WAY; 10/20/23-11/20/23 3693 CREEKSIDE PARK DR; 10/05/23-11/05/23	Acct:158231001 Acct:158231002 Acct:158231004 Acct:158231005 Acct:158231006 Acct:158231007 Acct:158231008 Acct:158231009 Acct: 186140001	\$ 265.61 ✓ \$ 54.57 ✓ \$ 1,364.19 ✓ \$ 64.02 ✓ \$ 916.60 ✓ \$ 40.64 ✓ \$ 41.76 ✓ \$ 35.90 ✓
3	Persson, Cohen, Mooney, Fernandez & Jackson District Counsel: November 2023	4433	\$ 588.00 ✓
4	PFM Group Consulting LLC Disclosure Fee S2016A/B: 10/01/23-09/30/24 District Management Fee: December 2023	128219 DM-12-2023-15	\$ 250.00 ✓ \$ 2,750.00 ✓
5	Southwest Maintenance Services Cleaning Services: December 2023	9216	\$ 480.00 ✓
6	Starner Pools Pool Maintenance: December 2023	28803	\$ 1,100.00 ✓
7	VenturesIn.com, Inc. Website Maintenance: December 2023	46658	\$ 80.00 ✓

TOTAL	\$ 8,706.57
--------------	--------------------

APPROVED: C. Chavez 12/21/23

Charles P. Chavez, Chairman
Board Member

RECEIVED

DEC 12 2023

TO AP

Venessa Ripoll

RECEIVED

DEC 19 2023

TO LAND

e
12/27/23

**CROSS CREEK
COMMUNITY DEVELOPMENT DISTRICT**



Payment Authorization No. 234
12/15/2023

Item No.	Vendor	Invoice Number	General Fund FY 2024
1	American Drilling of Sarasota Well Contact Switch	1778	\$ 500.00 ✓
2	Landscape Maintenance Professionals Irrigation Control Valve/Valve Box Replacement Bush Hog and Forestry Mulch Fence/Preserve	180554 180614	\$ 1,340.84 ✓ \$ 3,561.60 ✓
3	Manatee County Utilities (paid online) 4000 CREEKSIDE PARK DR; 10/17/23-11/16/23 12501 RYEGRASS LOOP; 10/17/23-11/16/23 12515 FRESHWATER RUN; 10/19/23-11/17/23	Acct: 187908-133094 Acct: 187908-134766 Acct: 187908-134768	\$ 1,379.21 ✓ CREDIT ✓ \$ 57.36 ✓
4	Peace River Electric (paid online) 3693 CREEKSIDE PARK DR; 11/05/23-12/06/23	Acct: 186140001	\$ 330.56 ✓

TOTAL **\$ 7,169.57**

APPROVED: *COMVIZ* 12/21/23

Vivian Carvalho

Charles P. Bay, Chairman
Board Member

ca
12/27/23

**Cross Creek
Community Development District**

Review of District Financial Statements

Cross Creek CDD
Statement of Financial Position
As of 10/31/2023

	General Fund	Debt Service Fund	Capital Projects Fund	Long Term Debt	Total
<u>Assets</u>					
<u>Current Assets</u>					
General Checking Account	\$21,657.53				\$21,657.53
Assessments Receivable	541,360.32				541,360.32
Assessments Receivable		\$49,058.70			49,058.70
Debt Service Reserve 2007A Bond		14,851.09			14,851.09
Debt Service Reserve 2007B Bond		9,540.18			9,540.18
Debt Service Reserve 2016AB Bond		221,338.59			221,338.59
Revenue 2007AB Bond		16,464.58			16,464.58
Revenue 2016AB Bond		9,778.37			9,778.37
Interest 2016AB Bond		2,458.08			2,458.08
Prepayment 2016A Bond		1,000.18			1,000.18
Sinking Fund 2016A Bond		17.27			17.27
Total Current Assets	<u>\$563,017.85</u>	<u>\$324,507.04</u>	<u>\$0.00</u>	<u>\$0.00</u>	<u>\$887,524.89</u>
<u>Investments</u>					
Amount Available in Debt Service Funds				\$275,448.34	\$275,448.34
Amount To Be Provided				159,551.66	159,551.66
Total Investments		<u>\$0.00</u>	<u>\$0.00</u>	<u>\$435,000.00</u>	<u>\$435,000.00</u>
Total Assets	<u>\$563,017.85</u>	<u>\$324,507.04</u>	<u>\$0.00</u>	<u>\$435,000.00</u>	<u>\$1,322,524.89</u>
<u>Liabilities and Net Assets</u>					
<u>Current Liabilities</u>					
Accounts Payable	\$99,973.85				\$99,973.85
Deferred Revenue	538,516.37				538,516.37
Deferred Revenue		\$49,058.70			49,058.70
Total Current Liabilities	<u>\$638,490.22</u>	<u>\$49,058.70</u>	<u>\$0.00</u>	<u>\$0.00</u>	<u>\$687,548.92</u>
<u>Long Term Liabilities</u>					
Revenue Bonds Payable - Long-Term				\$435,000.00	\$435,000.00
Total Long Term Liabilities		<u>\$0.00</u>	<u>\$0.00</u>	<u>\$435,000.00</u>	<u>\$435,000.00</u>
Total Liabilities	<u>\$638,490.22</u>	<u>\$49,058.70</u>	<u>\$0.00</u>	<u>\$435,000.00</u>	<u>\$1,122,548.92</u>
<u>Net Assets</u>					
Net Assets, Unrestricted	(\$48,936.70)				(\$48,936.70)
Current Year Net Assets, Unrestricted	41,630.30				41,630.30
Net Assets - General Government	(3,475.78)				(3,475.78)
Current Year Net Assets - General	(64,690.19)				(64,690.19)
Fund Balance - Unreserved		(\$1,185,850.00)			(1,185,850.00)
Net Assets, Unrestricted		4,778,699.49			4,778,699.49
Current Year Net Assets, Unrestricted		6.85			6.85
Net Assets - General Government		(3,317,408.00)			(3,317,408.00)
Net Assets, Unrestricted			(\$1,905,948.00)		(1,905,948.00)
Net Assets - General Government			1,905,948.00		1,905,948.00
Total Net Assets	<u>(\$75,472.37)</u>	<u>\$275,448.34</u>	<u>\$0.00</u>	<u>\$0.00</u>	<u>\$199,975.97</u>
Total Liabilities and Net Assets	<u>\$563,017.85</u>	<u>\$324,507.04</u>	<u>\$0.00</u>	<u>\$435,000.00</u>	<u>\$1,322,524.89</u>

Cross Creek CDD
Statement of Activities
As of 10/31/2023

	General Fund	Debt Service Fund	Capital Projects Fund	Long Term Debt	Total
Revenues					
Other Revenue	\$41,630.30				\$41,630.30
Total Revenues	<u>\$41,630.30</u>	<u>\$0.00</u>	<u>\$0.00</u>	<u>\$0.00</u>	<u>\$41,630.30</u>
Expenses					
Public Officials' Insurance	\$2,993.00				\$2,993.00
Trustee Services	1,346.87				1,346.87
District Management	2,750.00				2,750.00
Assessment Administration	5,000.00				5,000.00
Janitorial Service	480.00				480.00
Web Site Maintenance	80.00				80.00
Dues, Licenses, and Fees	175.00				175.00
Security	1,350.56				1,350.56
Electric	3,534.84				3,534.84
Water	808.72				808.72
Pool Maintenance	1,840.00				1,840.00
General Liability Insurance	3,960.00				3,960.00
Property & Casualty	9,801.00				9,801.00
Lake Maintenance	1,800.00				1,800.00
Landscaping Maintenance & Material	28,940.00				28,940.00
Pest Control	220.00				220.00
Total Expenses	<u>\$65,079.99</u>	<u>\$0.00</u>	<u>\$0.00</u>	<u>\$0.00</u>	<u>\$65,079.99</u>
Other Revenues (Expenses) & Gains (Losses)					
Interest Income	\$389.80				\$389.80
Net Increase (Decrease) in FV of Inv		\$6.85			6.85
Total Other Revenues (Expenses) & Gains (Losses)	<u>\$389.80</u>	<u>\$6.85</u>	<u>\$0.00</u>	<u>\$0.00</u>	<u>\$396.65</u>
Change in Net Assets	(\$23,059.89)	\$6.85	\$0.00	\$0.00	(\$23,053.04)
Net Assets At Beginning Of Year	<u>(\$52,412.48)</u>	<u>\$275,441.49</u>	<u>\$0.00</u>	<u>\$0.00</u>	<u>\$223,029.01</u>
Net Assets At End Of Year	<u><u>(\$75,472.37)</u></u>	<u><u>\$275,448.34</u></u>	<u><u>\$0.00</u></u>	<u><u>\$0.00</u></u>	<u><u>\$199,975.97</u></u>

Cross Creek CDD
Budget to Actual
For the Month Ending 10/31/2023

	Year To Date			FY 2024 Adopted Budget
	Actual	Budget	Variance	
Revenues				
Assessments	\$ -	\$ 44,520.42	\$ (44,520.42)	\$ 534,245.00
Other Revenue	-	-	-	-
Developer Contributions	-	-	-	-
Other Income and Financing Sources	41,630.30	3,416.67	38,213.63	41,000.00
Net Revenues	\$ 41,630.30	\$ 47,937.08	\$ (6,306.78)	\$ 575,245.00
General & Administrative Expenses				
Public Officials' Insurance	\$ 2,993.00	\$ 269.00	\$ 2,724.00	\$ 3,228.00
Trustee Services	1,346.87	708.33	638.54	8,500.00
District Management	2,750.00	2,750.00	-	33,000.00
Field Management	-	604.17	(604.17)	7,250.00
Engineering	-	41.67	(41.67)	500.00
Annual Disclosure	-	83.33	(83.33)	1,000.00
Property Appraiser	-	41.67	(41.67)	500.00
District Counsel	-	666.67	(666.67)	8,000.00
Assessment Administration	5,000.00	416.67	4,583.33	5,000.00
Reamortization Schedule	-	41.67	(41.67)	500.00
Audit	-	366.67	(366.67)	4,400.00
Arbitrage Calculation	-	41.67	(41.67)	500.00
Postage & Shipping	-	8.33	(8.33)	100.00
Copies	-	2.08	(2.08)	25.00
Legal Advertising	-	37.50	(37.50)	450.00
Office Supplies	-	12.50	(12.50)	150.00
Web Site Maintenance	80.00	40.00	40.00	480.00
Dues, Licenses, and Fees	175.00	14.58	160.42	175.00
Total General & Administrative Expenses	\$ 12,344.87	\$ 6,146.50	\$ 6,198.37	\$ 73,758.00
Field Expenses				
Electric	\$ 3,534.84	\$ 3,179.33	\$ 355.51	\$ 38,152.00
Propane	-	8.33	(8.33)	100.00
Water	808.72	1,000.00	(191.28)	12,000.00
Pool Maintenance	1,840.00	1,000.00	840.00	12,000.00
Contingency	-	743.17	(743.17)	8,918.00
General Liability Insurance	3,960.00	355.92	3,604.08	4,271.00
Property Insurance	9,801.00	866.67	8,934.33	10,400.00
Janitorial / Cleaning	480.00	816.67	(336.67)	9,800.00
Camera/Monitoring (Envera)	1,350.56	642.00	708.56	7,704.00
Lake Maintenance	1,800.00	1,250.00	550.00	15,000.00
Landscape Maintenance	28,940.00	11,000.00	17,940.00	132,000.00
Landscape Improvements/Irrigation Repair	-	2,928.50	(2,928.50)	35,142.00
Major Repairs & Replacements	-	15,833.33	(15,833.33)	190,000.00
Contingency/Property Improvements	-	2,083.33	(2,083.33)	25,000.00
Pest Control	220.00	83.33	136.67	1,000.00
Total Field Expenses	\$ 52,735.12	\$ 41,790.58	\$ 10,944.54	\$ 501,487.00
Total General, Administrative Expenses & Field Expense	\$ 65,079.99	\$ 47,937.08	\$ 17,142.91	\$ 575,245.00
Total Expenses	\$ 65,079.99	\$ 47,937.08	\$ 17,142.91	\$ 575,245.00
Income (Loss) from Operations	\$ (23,449.69)	\$ -	\$ (23,449.69)	\$ -
Other Income (Expense)				
Interest Income	\$ 389.80	\$ -	\$ 389.80	\$ -
Total Other Income (Expense)	\$ 389.80	\$ -	\$ 389.80	\$ -
Net Income (Loss)	\$ (23,059.89)	\$ (0.00)	\$ (23,059.89)	\$ -